

# How to update T32MZ

Your Futaba T32MZ transmitter programming can be updated easily and at no cost online. When functions are added or improved, the update file can be downloaded from our website. Copy the update files to the microSD card and then use the following procedure to update the program.

Check our web site for the FAQ regarding updating for more information.

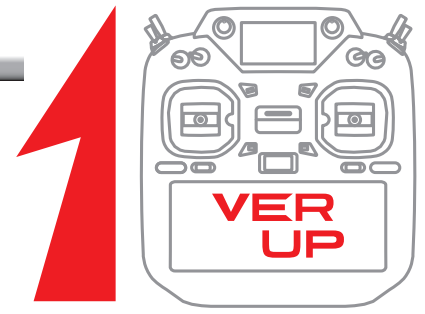

## Updating procedure

**Note:** If the battery fully discharges during program updating, updating will fail. When the remaining battery capacity is 50% or less, always recharge the battery before updating.

**Note:** The model data in the transmitter can be used unchanged after updating, but to be safe, back up the model data before updating

1. Download the zip file of the update data from our website or your local distributor's website.

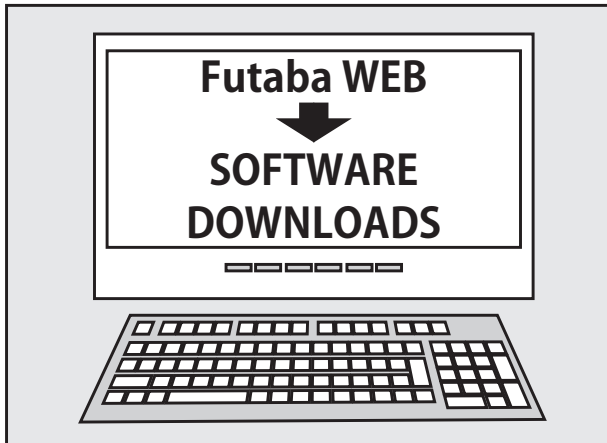

2. Extract the zip file on your computer.

3. The "Update" folder will be created on your computer.



4. Copy the "Update" folder onto your microSD card.

5. Insert the microSD card containing the update file into the card slot.

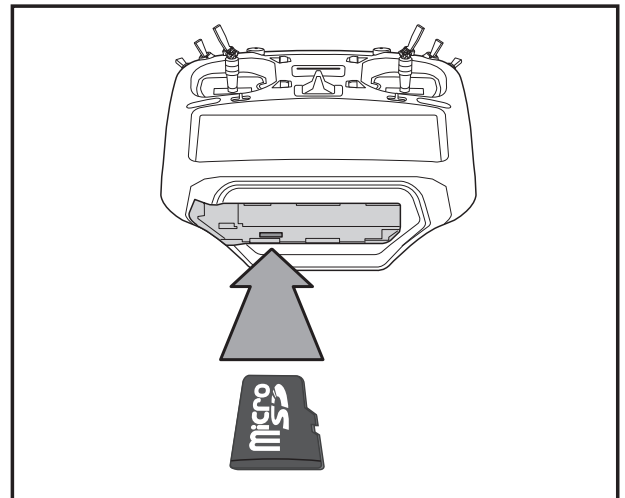

6. Press the HOME/EXIT button first. And next turn on the transmitter power.

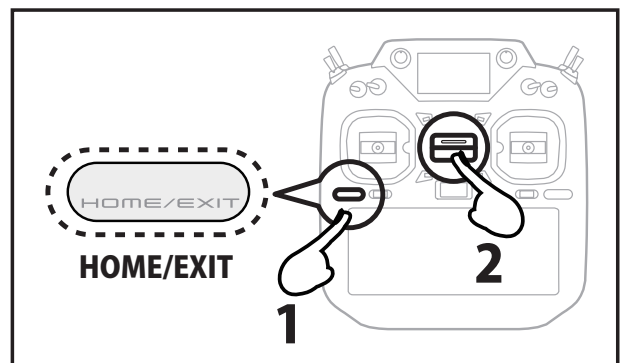

7. Keep pressing the HOME / EXIT button.

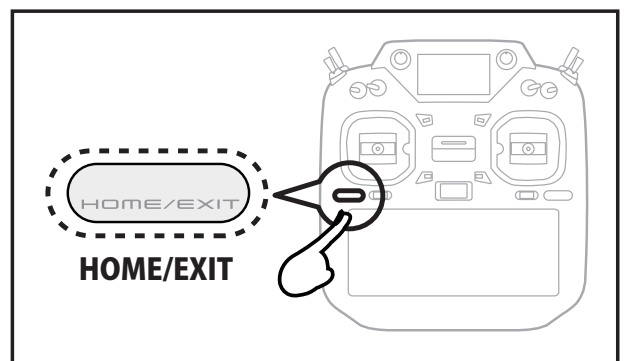

- 8.** Release the HOME / EXIT button when "Push any button to start the update."

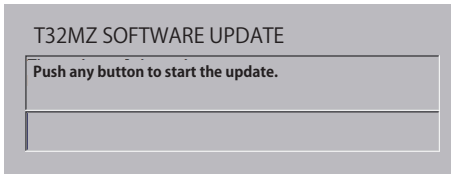

- 9.** Press the HOME / EXIT button or U.MENU/MON button.

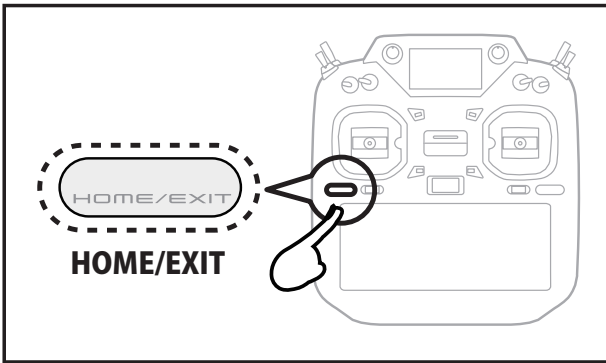

- 10.** The update starts and the screen changes as follows.

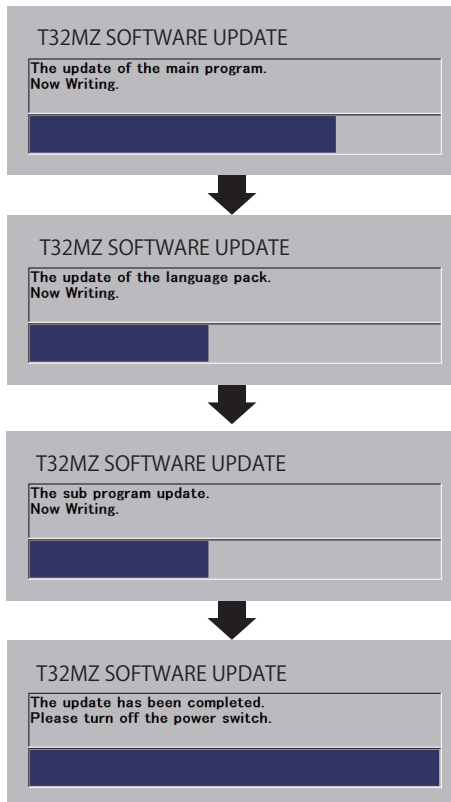

- 11.** When the update completion message appears, turn off the power and remove the microSD card.

- 12.** Be sure to check the each function before use.



**Don't disconnect or remove the battery and microSD card from the transmitter during the update.**

**\* Voice data will be installed when the power is turned on for the first time after the update. No special operation is required, so please wait for a while. From the second time onward, the power will be turned on as usual.**

This software updates or alters the functions and features noted below. The instructions and information that follow are meant as a supplement to the original instruction manual that accompanied the T32MZ transmitter. Please refer to the original instruction manual where applicable, but replace the steps indicated below with these instructions. Please note that the software update will be finalized the first time that the T32MZ is powered up, after the software has been applied. As such, it may require a few moments before the Start screen appears. Please check to ensure that the update has been installed.

- 1) Select the System Menu.
- 2) Touch the [Information] button.
- 3) Confirm that the information in the display indicates the Editor and Encoder version numbers as noted above.

**1. GYA483 Airplane gyro support → Refer to T32MZ(WC)-GYA483 Setting manual**

**2. The settings for the GYA573 aircraft gyro now include a setting for the steering (RUD4) gyro function. → Refer to Refer to T32MZ(WC)-GYA573 Setting manual**

**1. Failsafe Delay function newly added.**

By connecting a receiver that supports the failsafe delay function, can turn the fail-safe delay function ON/OFF.

This function enables the servo movement softly toward the preset failsafe position when the failsafe activated.

Also when back to normal operation the servo movement softly back to the position of under controlled.

To enable this function, please go to Receiver Setting menu in the "System Menu" of the transmitter.

This delay function is valid for all channels set failsafe and not able to set each channel independently.

※ This function is valid for Battery Failsafe as well.

The receivers that support the failsafe delay function are as follows:

\*The firmware update of the correspond receivers is necessary to use this function.

Receiver	Supported Versions
R7208SB R7308SB	V2.3~
R7206SB R7306SB	V1.3~
R7214SB R7314SB	V1.3~
R7201SB R7301SB	V1.4~

1. Connect the receiver's S.BUS2 port to the transmitter's S.I/F port with the receiver setting/update cable.
2. Tap [Receiver setting] on the [System menu]
3. Tap [Read]
4. Select ON/OFF for the Failsafe delay function.

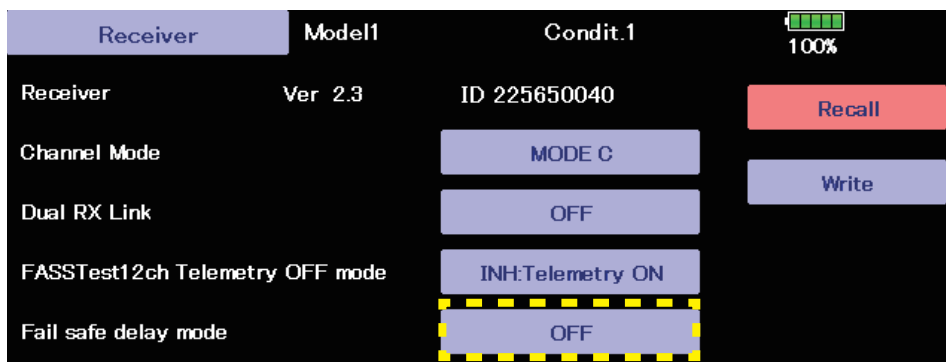

\*If a receiver version that does not support the failsafe delay function is connected, the failsafe delay setting button will not be displayed. Update your receiver to the latest version.

5. Tap [Write]
6. Remove the receiver.

(Editor Version: 4.5.1 Encoder version: 2.2)

## 1. Fixes a bug that caused model data created in previous versions to malfunction.

(Editor Version: 4.5.0 Encoder version: 2.2)

## 1. GYA573 Ver.6.x New firmware support → Refer to T32MZ(WC)-GYA573 V.6.x Setting manual

Added Vector Nozzle function for jet models.

Camber mixing setting rate has been expanded from  $\pm 100$  to  $\pm 200$ .

## 2. Now compatible with Power Hub DLPH-3.

By connecting the DLPH-3 to the transmitter, it is possible to change the mode of the DLPH-3.

- ① Connect the DLPH-3 to the transmitter as shown.

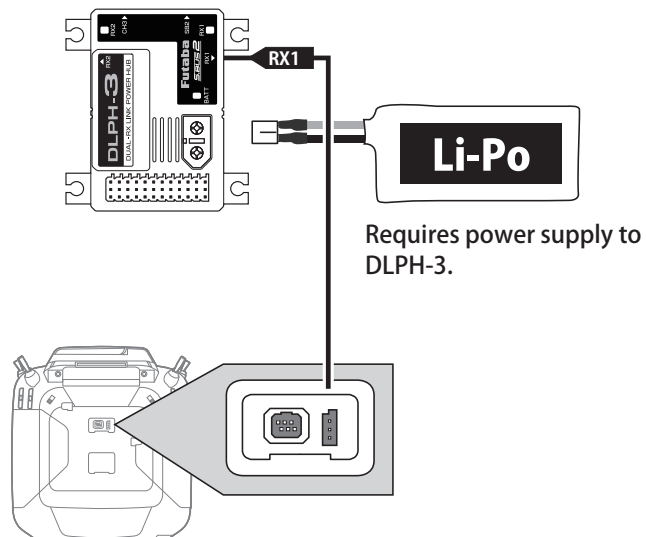

- ② Call up the System Menu → DLPH screen.

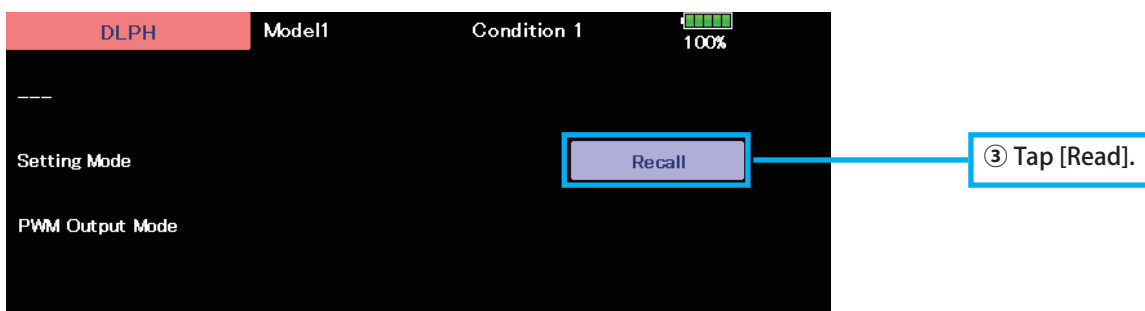

④ The version of the connected DLPH-3 is displayed.

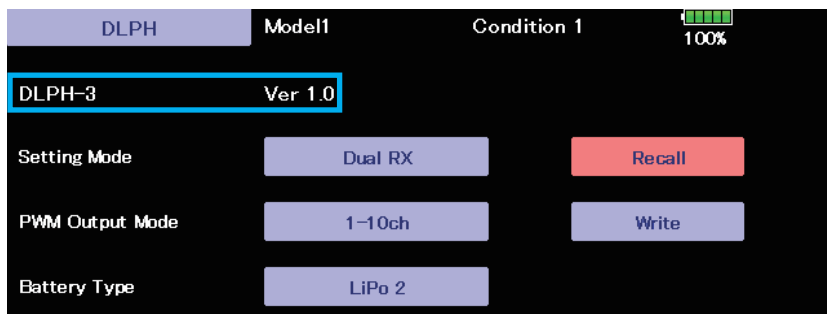

If reading fails, the above message will be displayed. Check the connection.

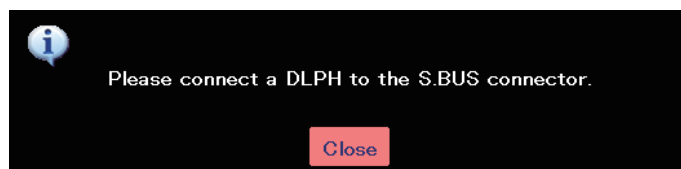

⑤ Set the mode of the DLPH-3.

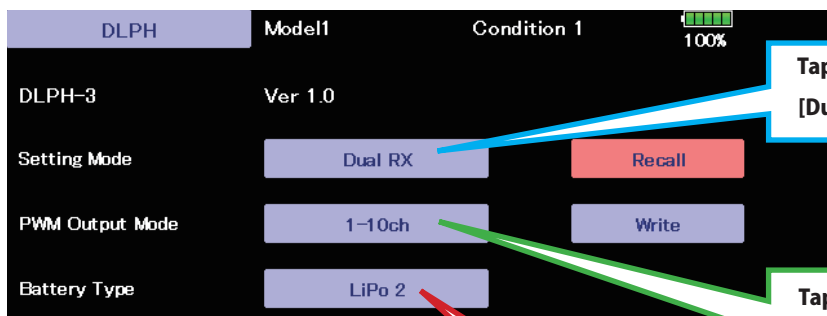

Tapping the Setting mode switches as follows:

[Dual Rx] → [Single Rx] → [Airplane Gyro] → [Dual Rx] → ...

When the setting mode is set to [Airplane Gyro], the PWM output mode is fixed to [1-10ch].

Tapping the PWM output mode switches as follows:

[1-10ch] → [11-20ch] → [21-24ch] → [1-10ch] → ...

Tapping the Battery type switches as follows:

[LiPo 2] → [LiFe 2] → [LiPo 3] → [LiPo 2] → ...

⑥ Tap Write, a confirmation screen will appear. Tap "Yes" to write the settings to the DLPH-3.

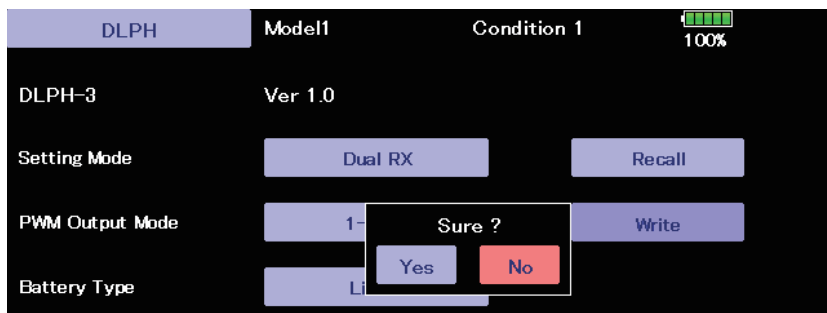

If writing fails, the above message will be displayed. Check the connection.

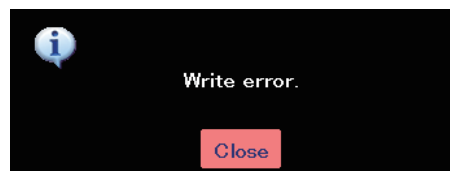

(Editor Version: 4.4 Encoder version: 2.1)

---

1. GYA573 New firmware support. → Refer to T32MZ GYA573 Setting manual

(Editor Version: 4.3 Encoder version: 2.1)

---

1. GYA553 New firmware Version 4.x support. → Refer to T32MZ GYA553 V4 Setting manual

(Editor Version: 4.1 Encoder version: 2.0)

---

1. CGY770R support. → Refer to T32MZ CGY770R Setting manual

---

## 2. Added confirmation screen to trainer function

A confirmation screen has been added when switching between Teacher and Student on the **System Menu** → **Trainer** screen.

Tap "**Yes**" to switch.

---

## 3. Confirmation screen has been added when the power is turned off.

The confirmation screen can be set in **System Menu** → **H/W Setting** → **Power Switch**.

If you set it to **ACT**, a confirmation screen will appear when you turn the power off. The power will not be turned off unless you tap "**Yes**."

## 1. Add FASSTest 26CH

FASSTest 26CH has been added to **Linkage menu** → **System Type**.

● **FASSTest 26CH** is a maximum 26 channels (linear 24 channels +switch 2 channels) 2.4 GHz dedicated system.

● In the **FASSTest 26CH** system, the channels that can be used on the S.BUS/S.BUS2 port are different.

- S.BUS port : 1 - 16 channel
- S.BUS2 port : 1 - 24 channel

When using channels 17 to 24 with S.BUS connection, connect the S.BUS2 servo to the S.BUS2 port of the receiver.

### ● Triple receiver function

Triple receivers can be linked with the **FASSTest 26CH**. Three receivers are recognized individually by ID numbers.

A telemetry function cannot be used for the 2nd/3rd receiver. The voltage and Ext voltage of a 2nd/3rd receiver cannot be known with a transmitter.

• Battery fail-safe voltage setup

A telemetry function cannot be used for the 2nd/3rd receiver. The voltage and Ext voltage of a 2nd/3rd receiver cannot be known with a transmitter.

#### Compatibility of FASSTest 26CH with receivers :

##### FASSTest 26CH compatible receivers

- R7208SB/R7308SB (V2.0~)
- R7206SB/R7306SB (V1.0~)
- R7214SB/R7314SB (V1.0~)
- R7201SB/R7301SB (V1.0~)

\*FASSTest 26CH cannot be used with receivers other than compatible models.

\*FASSTest 26CH cannot be used with R7208SB/R7308SB (V1.0) released before December 2023. (Available with Ver.UP)

\*All FASSTest receivers released after December 2023 will be compatible with FASSTest 26CH.

### About FASSTest26CH S.BUS2 connect and servos :

When using the following servos with the FASSTest 26CH system S.BUS2 connect , it is necessary to software version up the servos.

HPS-A703 (Serial number less than 22597)

HPS-AA702 (Serial number less than 20372)

HPS-HC701 (Serial number less than 10910)

HPS-HT700 (Serial number less than 10730)

HPS-H701 (Serial number less than 10361)

Servos other than those listed here can be used as is.

Updating requires a PC that can connect to the Internet and Futaba CIU-3.  
Refer to Futaba homepage for update software and update method.

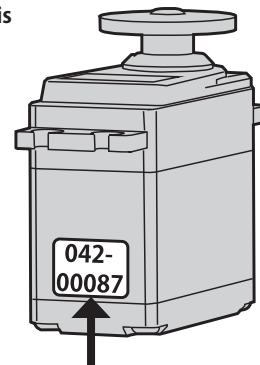

Serial number

The FASSTest 26CH mode is a new system that is ideal for those who need more channels, such as on large models. When using a conventional system (T-FHSS, FASSTest18CH, etc.), the above servos can be used as is without updating.

FASSTest 26CH and PWM connections do not require servos updates.

# 1. Add DLPH-2 setting function.

DLPH-2 mode setting can be performed on the T32MZ screen by wiring the DLPH-2 as shown in the figure.

1. Connect DLPH-2 to the transmitter as shown in the diagram on the right.
2. Call the **System menu** → **DLPH-2** screen.
3. Tap **Recall**

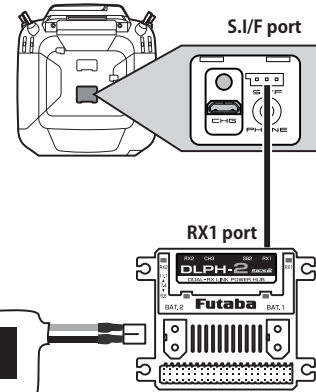

Connect the battery to DLPH-2.



4. The version of the connected DLPH-2 will be displayed.

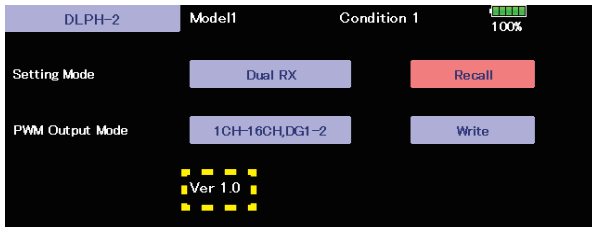

If it fails, the following message will appear. Check the connection.

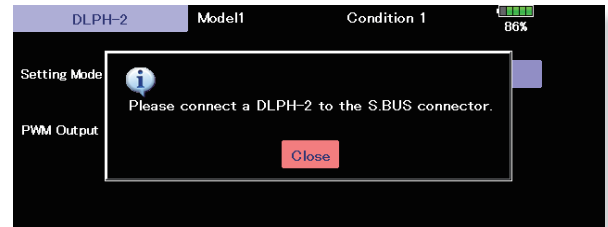

5. Configure the DLPH-2 mode settings.

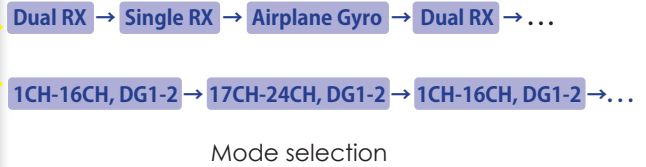
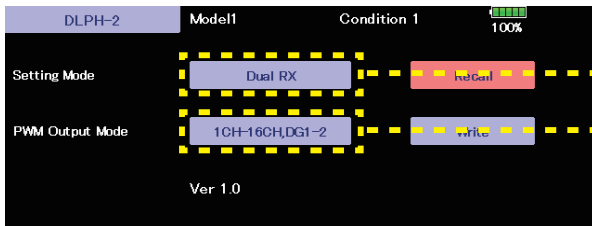

Mode selection

When setting mode is set to **[Airplane Gyro]**, PWM output mode is fixed to **[1CH-16CH, DG1-2]**.

6. Tap "Write", a confirmation screen will appear. Tap "Yes" to write the setting value to DLPH-2.

If it fails, the following message will appear. Check the connection.

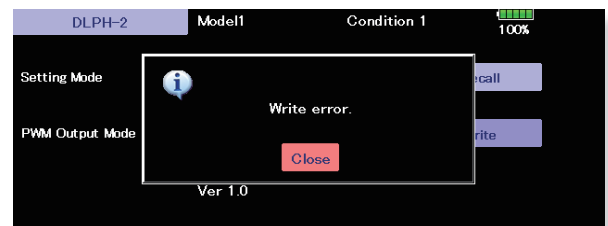
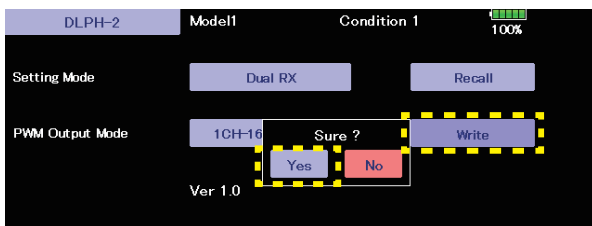

\*DLPH-2 is a HUB with a safety function that connects two batteries, two receivers, and a servo. For the functions of DLPH-2, please refer to the DLPH-2 manual.

## 2. Add Receiver setting function.

Receiver mode setting can be performed on the T32MZ screen by wiring the receiver as shown in the figure.

Compatible receivers are as follows. (As of January 2024)

- R7208SB/R7308SB (Compatible with software version 2.0 or later)
- R7206SB/R7306SB
- R7214SB/R7314SB

1. Turn on the power switch while pressing the **U.MENU/MON** button on the transmitter.

2. "No" tap.



\*For safety reasons, receiver settings cannot be made while radio waves are being transmitted.

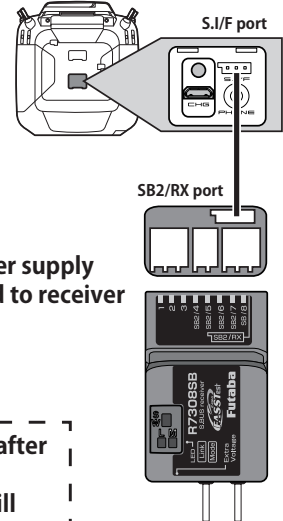

3. Connect receiver to the transmitter as shown in the diagram on the right.

4. Tap **Recall**



Tap Recall within 10 seconds after connecting the receiver.  
If 10 seconds pass, an error will occur, so please try again.

5. The version/ID of the connected receiver will be displayed.

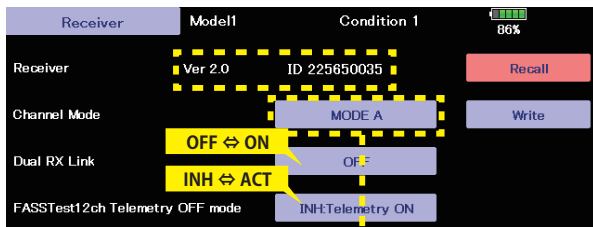

If it fails, the following message will appear. Check the connection.

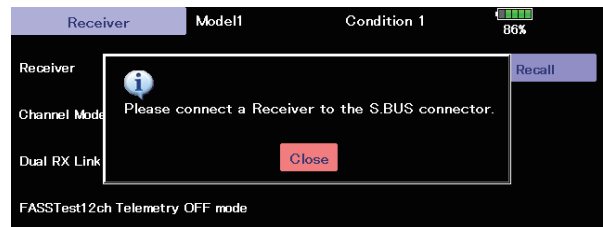

6. Tap **Channel Mode** to set the receiver mode.

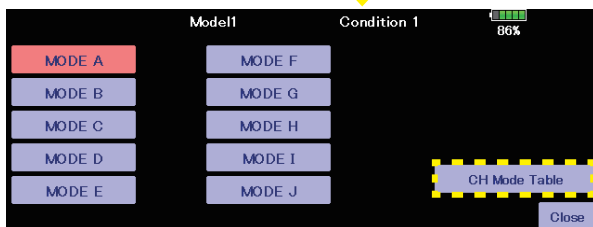

Select CH mode

Tap the **CH Mode Table** to display the channel mode table of the loaded receiver.

Port	MODE A	MODE B	MODE C	MODE D	MODE E	MODE F	MODE G	MODE H	MODE I	MODE J
1	1	1	1	1	9	9	9	17	17	17
2	2	2	2	2	10	10	10	18	18	18
3	3	3	3	3	11	11	11	19	19	19
4	4	4	4	S.BUS2	12	12	12	20	20	20
5	5	5	5	S.BUS2	13	13	13	21	21	21
6	6	6	6	S.BUS2	14	14	14	22	22	22
7	7	7	S.BUS2	S.BUS2	15	15	S.BUS2	23	23	S.BUS2
8	S.BUS	S.BUS	S.BUS	S.BUS	16	S.BUS	S.BUS	24	S.BUS	S.BUS

7. Tap "Write", a confirmation screen will appear. Tap "Yes" to write the setting value to receiver.

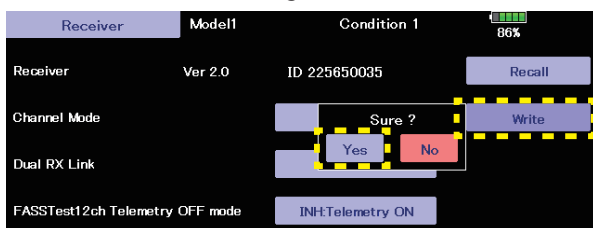

If it fails, the following message will appear. Check the connection.

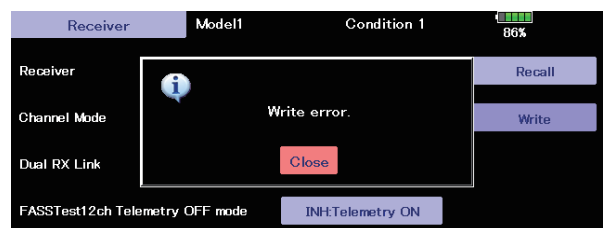

## 1. Telemetry settings: Added gear ratio setting button to Kontronik ESC and Scorpion ESC.

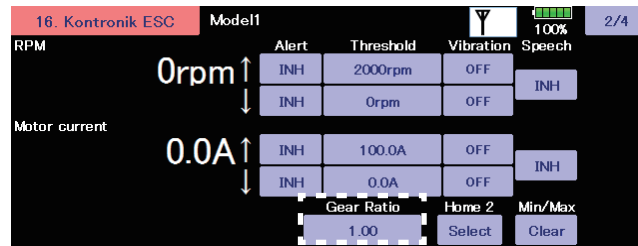

•If the gear is down, enter the gear ratio to display the helicopter rotor speed and the airplane gear down propeller speed.

## 2. Telemetry settings: Changed the motor pole number setting for each ESC to "100".

Previously, the number of poles was up to 36, but now it can be set up to 100.

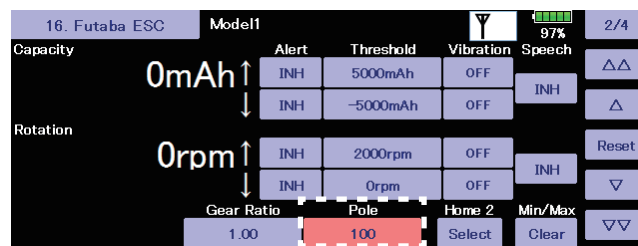

•Enter the number of poles for your motor.

## 1. Telemetry display bug fix

Fixed a bug that caused the telemetry display on the sub display to be distorted when the Unit System was set to "Yard-pound".

## 1. GYA553 New firmware Version 3.x support. → Refer to T32MZ GYA553 V3 Setting manual

Airplane Gyro GYA553 is compatible with 3rd aileron and 4th aileron.

## 1.Fixed user menu issue.

Fixed a bug that some screens registered in the user menu were not displayed when loading model data of V3.3.1 or earlier with T32MZ with software version V3.4.0 or later.

For software versions V3.4.0 to V3.6.0, re-register the screens that are not displayed in the user menu.

# 1. GYA553 New firmware Version 2.x support. → Refer to T32MZ GYA553 V2 Setting manual

- 1. CH3 (THR) can be output to the RUD2 / S.BUS2 port.
- 2. The Holding Power rate of the aircraft in AVCS mode has been expanded to 5 types from C1 to C5, and each rate can be set by switching the display.
- 3. Added the setting of switching CH of Holding Power rate C1 to C5 to S.BUS basic menu.

◆ **Config screen** There are 7 pages in total, and the additional functions are 1 page and 6 pages.

The software version of the connected GYA553 is displayed.

Tap to the basic menu

Added CH3 (THR) to the output item of RUD2 / S.BUS port

◆ **Basic Menu screen**

To "Config"

To "SBus Basic"

C1-C5 switch button

With the switch button, the "holding power" of each rate (C1 to C5) can be displayed and adjusted.

Added the setting of switching CH of holding power rate C1 to C5 to S.BUS basic menu.

◆ **S.BUS Basic screen** The second page has been added, and the total number of pages has changed from 2 to 3.

Additional page

Tap to move to the rate switching CH setting page.

Holding Power C2 to C5

Tap the CH used for rate switching to select it.

The current rate numbers C1 to C5 are displayed by operating the channel of the transmitter.

Like the flight condition function of the transmitter, you can set up to 5 different data for the attitude holding force rate of the aircraft in AVCS mode by operating the switch from the transmitter, and switch between them. You can set the holding power rate selector switch to the channel with the AFR function of the transmitter, and set the point for each rate on the AFR point curve to switch. It is also possible to use the flight condition function to work with the flight condition switch.

### Config 6/7



Display and adjust the current rate numbers C1 to C5 by operating the channel on the transmitter.

### S.BUS Basic 2/3

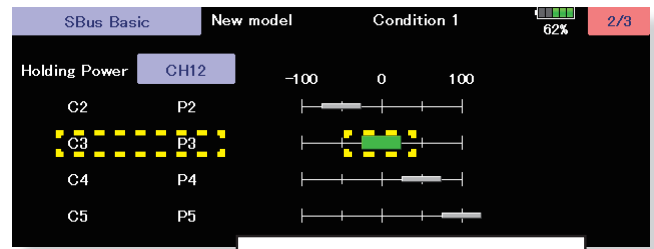

By operating the channel of the transmitter, the channel position of the current rate numbers C1 to C5 will be displayed in green.

When set to SW of DG1 or DG2

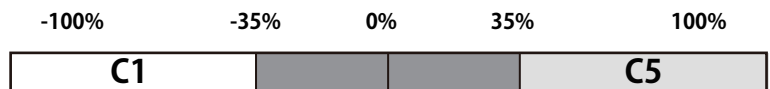
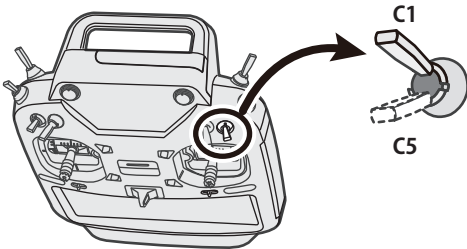

When set to dial or lever

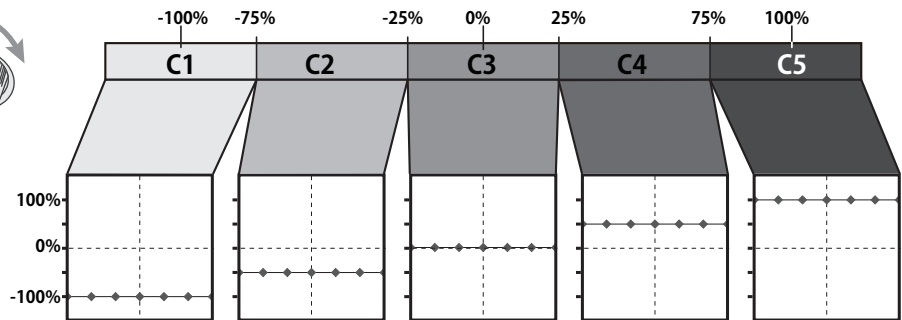
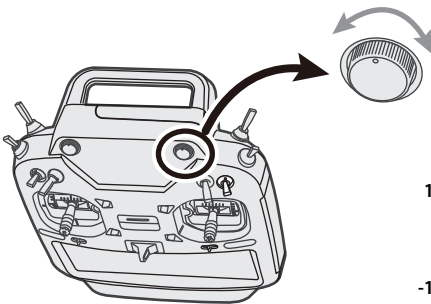

1.Fixed an issue where the integration timer malfunctioned while the screen was off.

1.Fixed the display of the sub display.

### 1. Futaba ESC, Hobbywing ESC telemetry compatible

Supports the telemetry function of the Futaba sensor "Futaba ESC" and the Hobbywing sensor "Hobbywing ESC".

Corresponding **Futaba ESC**

For details on **Hobbywing ESC** telemetry support, refer to the Hobbywing website.

#### Futaba ESC

MC-980H/A MC-9130H/A MC-9200H/A

◆ Register the ESC with the transmitter.

Linkage menu → Sensor → 2/2

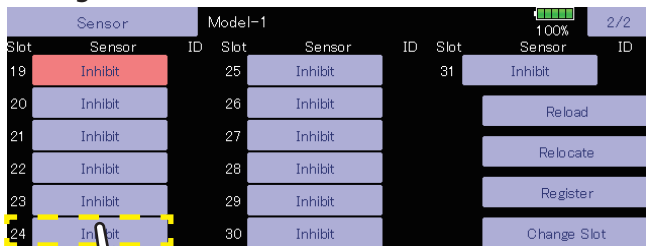

Tap the slot 24

◆ If slot 24 is used for another sensor

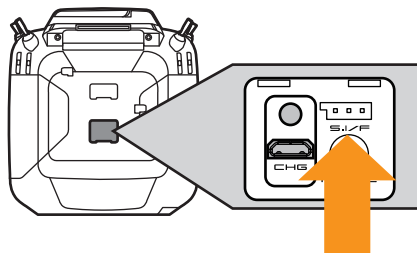

Connect the SBM-2 to the S.I / F port on the back of the transmitter.

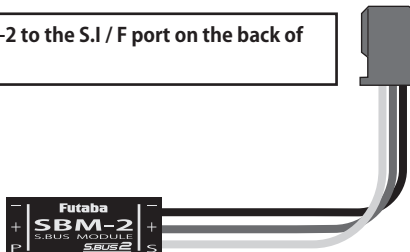

Linkage menu → Sensor → 2/2

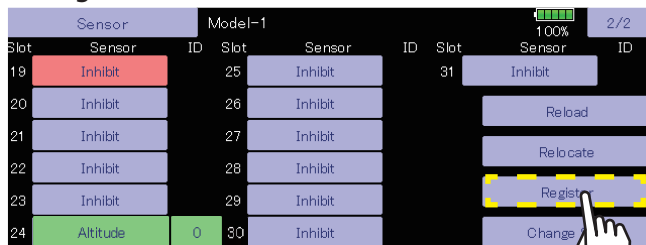

Tap register

1. Select **[Sensor]** on the second page of the linkage menu.
2. Open the second page of the sensor screen and tap the **Slot 24** button.
3. A list of sensors will be displayed, so select **Futaba ESC**.

1. Connect the **SBM-2** to the **S.I/F** port in the rear of the transmitter.
2. Open the sensor unit setting screen by touching the **[Sensor]** button in the Linkage Menu.
3. Touch the 1/2 to enter the second page of the Sensor screen. Then, touch the **[Register]** button.
4. If registration is successful, the following screen will appear. **"The registering succeeded."** Close the message by touching the [Close] button.

5. If registration failed, a screen like the following will appear: **"There are not enough available slots"**

SBM-2 require 8 slots for their operation. If continuous slots are not available, SBM-2 will not be registered accordingly. If there are unused slots, but they are not continuous, please use the Sensor Unit Reallocation feature, which follows, to change the slots of the existing sensors to accommodate the sensors which require continuous slots.

-**SBM-2**: 8 slots required

**"The connected sensor is not ready"**

No response from sensor unit. Check the connections.

◆ **The registered ESC will be displayed as "Futaba ESC".**

**The registered Hobbywing ESC is displayed as "Hobbywing ESC".**

For details on Hobbywing ESC telemetry support, refer to the Hobbywing website.

◆ MC-9130H/A telemetry connection example

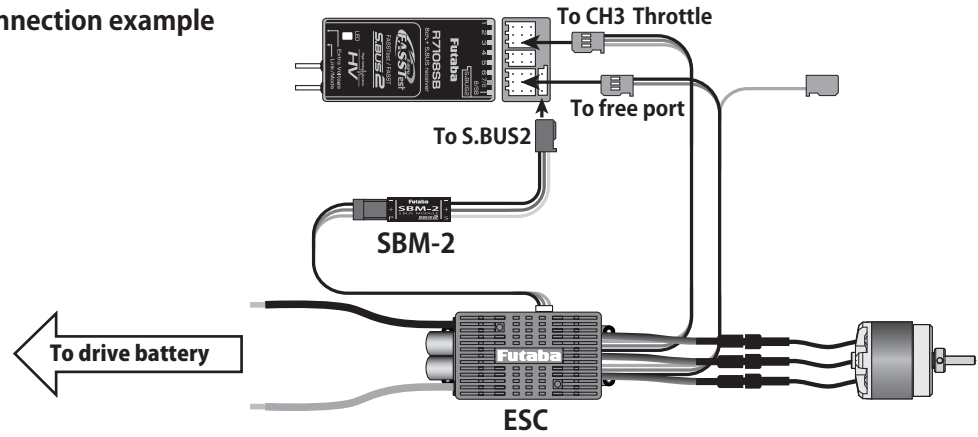

◆ ESC telemetry display screen

The ESC status is displayed. Alarm setting is also possible.

• Press to setup vibration alerts. 4 types of vibration selections are possible.

• INH → ACT ;When activated a voice alert will also sound in addition to the alarm.

- Display of each current numerical value
- This display is the maximum and minimum after starting reception until the transmitter is turned off.
- A up arrow shows that the alarm operates, when the set value is exceeded.
- A downward arrow shows that the alarm operates, when less than the set-up numerical value.

◆ Current Voltage

• Change of a numerical value

• Press to setup an alert.

• Selects the sensor displayed on home 2 screen.

• Displays the maximum and minimum voltage ranges. [Clear] to reset.

◆ Capacity RPM

• The current and capacity consumption display may vary depending on the usage conditions, so use it as a guide.

- If the gear is down, enter the gear ratio to display the helicopter rotor speed and the airplane gear down propeller speed.
- Enter the number of poles for your motor.

◆ ESC Temperature

◆ Throttle

- Shows the output level from the ESC to the motor, not the position of the throttle stick.
- Even if the stick is in the 50% position, the output may not be 50% depending on the ESC setting.

- When enabled, the alarm will be activated in the following warning state.
- When enabled, the vibrator will start in the following warning state.

◆ Warning state

Throttle not at 0%	When the throttle stick is not low when ESC is started
Low voltage	When the battery voltage is below the cutoff voltage
Over temperature	When the ESC temperature is 110 °C or higher
Over current	Peak current over
Motor locked	When the motor locks
Throttle signal lost	When no throttle signal is received for more than 0.25 s

## 2. Add R.P.M. display : Gov Basic

The number of revolutions of the governor setting is displayed on the governor basic screen of the gyro setting.

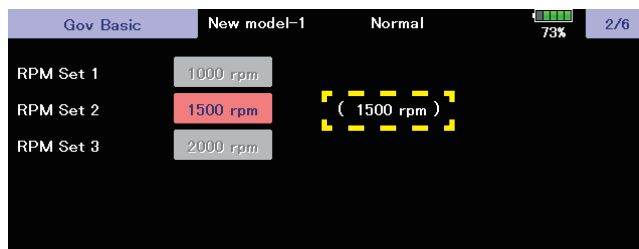

## 3. GYA553 Addition of setting parameters

AIL / ELE / RUD holding power setting has been added to the setting parameters of GYA553.

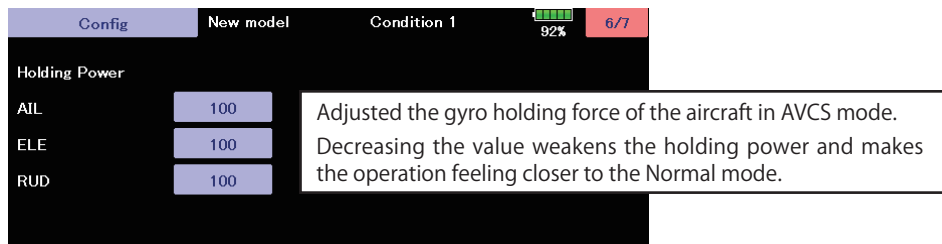

## 4. Expansion of governor R.P.M. range

With the governor function of the model menu, the R.P.M. range has been expanded to 700 to 3500 rpm.

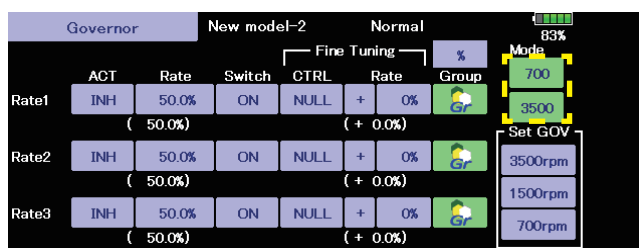

(Editor Version: 3.4 Encoder version: 1.2)

## 1. Add GYA553 Airplane Gyro setting function. (Refer the T32MZ GYA553 Setting Manual)

## 2. Compatible with SCORPION ESC telemetry

Added support for SCORPION POWER SYSTEM ESC some models.

## 3. Add power off switch press time setting

The power switch long press time when turning off the power can be selected from 1 second and 4 seconds.

[SYSTEM MENU] → [H/W Setting]

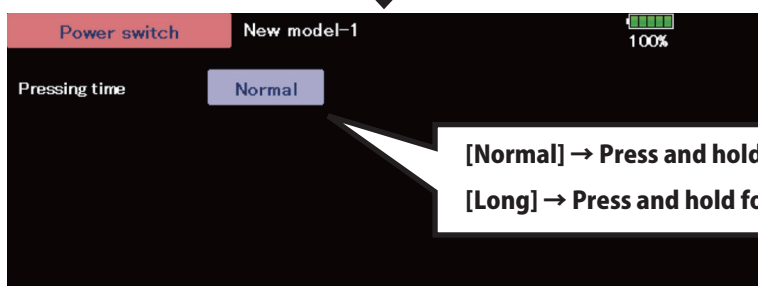
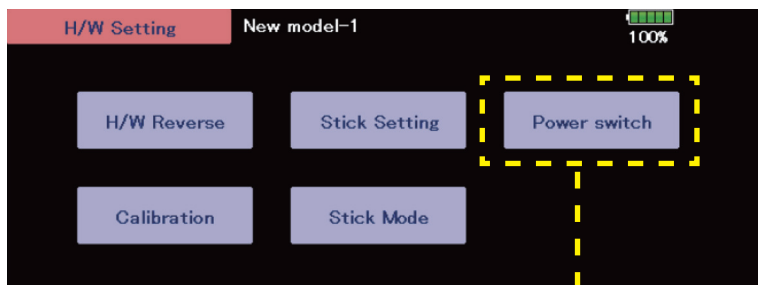

(Editor Version: 3.3.1 Encoder version: 1.2)

1. Fixed the CGY755/CGY760R Gyro setting function.

(Editor Version: 3.3 Encoder version: 1.1)

1. Add CGY755/CGY760R Gyro setting function. (Refer the T32MZ Ver 3.3 Gyro Setting Manual)

(Editor Version: 3.2.1 Encoder version: 1.1)

1. Fixed a defect on the screen off function.

(Editor Version: 3.2 Encoder version: 1.1)

### 1. Add Screen off function [Quick start]

This "screen off" can quick start next startup. This is convenient when turning on and off frequently. No RF output at "screen off". Also, there is no screen display. However, the battery is consumed because the internal circuit is activated.

Be sure to turn off the receiver first.

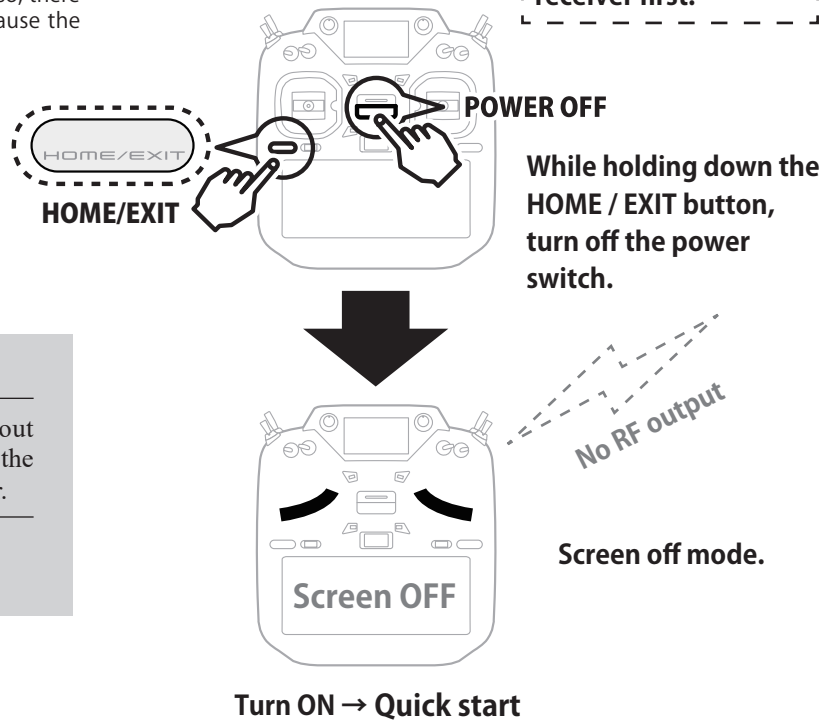

#### ⚠ WARNING

- ⚠ While in screen off mode, it consumes about 4% of the battery per hour. If you do not use the transmitter for a long time, turn off the power.
- ⚠ Updates cannot be performed in screen off mode. To update, turn off the power.

### 2. Add Stop alarm : Telemetry RPM sensor setting

On the telemetry setting screen, if you enable the alarm setting on the low rotation side of the RPM sensor and set the alarm setting to 0, an alarm will be activated when the rotation speed becomes 0.

### 3. Chinese language support

Added support for Chinese display. You can select Chinese by updating to Chinese version software.

### 4. GPS display correction

Fixed an issue where GPS location information could not be recognized correctly.

### 5. Sub display External input voltage display correction

Fixed the problem that the voltage was displayed low when the external input voltage of the receiver on the sub-display exceeded 25.5V.

### 6. KS-01 (O.S.ENGINE)

Added support for a kill switch KS-01 made by O.S.ENGINE.